

TRINITY CENTRE BRISTOL

SOUND REINFORCEMENT SYSTEM SPECIFICATION

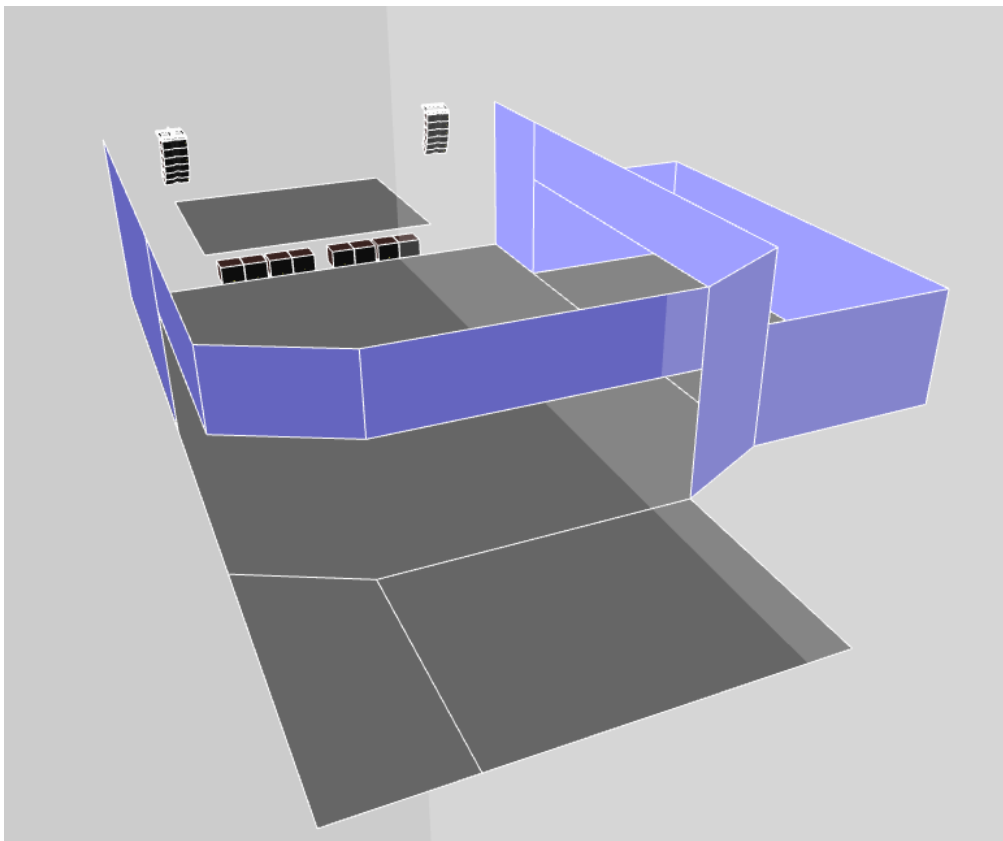



1 Contents.

1. An Introduction to L Acoustics.
2. Principles of the sound design.
3. Speaker system identification.
4. Amplified controllers.
5. Loudspeaker rigging charts.
6. Modelling.
7. Schematics
8. Technology overview
9. Datasheets
10. Warrenty
11. References



2 An introduction to L Acoustics.

The L-ACOUSTICS® Rental Network community is represented by 450 rental agents employing 3000 system technicians and operating more than 40,000 WST® enclosures. The Network provides a unique opportunity for each agent to heighten their profile and establish human and technical standards. Network agents can pool inventories and develop cross-rental activity to adjust to rental market peaks. Technicians have access to expert system training seminars, advanced product support, first show assistance and sound design advice from the L-ACOUSTICS® application team. Touring engineers benefit from using tools such as the SOUNDVISION 3D electro-acoustic simulation software and since 1984 L-ACOUSTICS® has revolutionized the professional audio industry with its legendary line source systems, developing a reputation for creating innovative solutions for the most demanding sound reinforcement requirements.

L-ACOUSTICS® is committed to designing and manufacturing sound systems with the highest, most consistent and predictable performance levels, packaged as complete systems and adhering to universal standards.

Innovation and scientific methods have been L-ACOUSTICS®' principles from the outset, originally rooted in the fields of physics and fundamental acoustics, the company is best known as the inventor of modern line source arrays thanks to its published research on Wavefront Sculpture Technology® and the legendary V-DOSC® system. L-ACOUSTICS® has regularly published and presented its research work to the scientific community.

Innovation Milestones

- 1984 : Physicist Dr. Heil founds L-ACOUSTICS®
- 1989 : First coaxial system MTD115/LLC
- 1992 : Wavefront Sculpture Technology (WST®)
- 1994 : V-DOSC® and Network
- 1995 : ARCS® Constant Curvature Array
- 1999 : dV-DOSC modular line source
- 2004 : SOUNDVISION simulation software
- 2005 : KUDO® and K-LOUVER® variable directivity
- 2006 : P series self-powered coaxials
- 2007 : Amplified controllers, SB28, KIVA/XT series
- 2008 : K1/KUDO® pilot program
- 2009 : New Rental Network
- 2010 : KARA®, SB18 (laminar vent). System integration charter
- 2011 : LA NETWORK MANAGER 2.0
- 2011 : ARCS® II
- 2012 : ARCS® WIDE, ARCS® FOCUS, SB18m, SB15m and 5XT
- 2014 : K2
- 2015 : SOUNDVISION 3.0



All L-ACOUSTICS® systems are innovatively created with exceptional longevity, representing the best possible investment. Our dedication to technical support, user education and sound design, all contribute to making L-ACOUSTICS® not only a loudspeaker manufacturer but a partner dedicated to supporting its customers.

Over time L-ACOUSTICS® has deployed its research activity into the fields of structural engineering, power electronics, signal processing and digital networks, developing its own in-house simulation and modeling tools and conducting practical experimentation to observe and validate its models.

Complete System Approach:

Our universal system approach covers multiple aspects of sound reinforcement including: simulation tools, amplified controllers, preset libraries, signal distribution and cabling, transport and rigging to offer our clients complete solutions at the highest, most predictable level of performance.

Rentals:

Venue database is available to optimize sound design and system set-up off-site.

Permanent Installations:

L-ACOUSTICS® boasts more than 1600 referenced installations in 60 countries. The System Integrator Charter embraced by the Network of contractors offers a systematic project methodology and palette of services covering: design-build project analysis, electro-acoustic and mechanical specification, installations, system tuning, commissioning and training by highly qualified personnel following precise protocols. Design-build integrators benefit from a dedicated factory support and training program. Consultants can rely on the L-ACOUSTICS® System Integrators for projects awarded through a bidding process. Designers can benefit from modeling tools using either SOUNDVISION or bridges to industry standard acoustic software and integrate L-ACOUSTICS® systems seamlessly with AMX® and Crestron® platforms.

L-ACOUSTICS offers dedicated UK technical support to assist with everything from venue design specifications, on-site show assistance along with dedicated UK training seminars. Outside the UK there is a large team of application engineers available at the L-ACOUSTICS headquarters in Paris, France.

3 Principles of the sound design.

The system proposed has been designed for amplifying and improving the intelligibility of speech and music playback throughout the venue. The sound sources are chosen and optimized with respect to the coverage of the audience sections. The objective is to maintain an even SPL and smooth tonal balance throughout the venue. Considering the geometry of the room there is a need for a system with good control of vertical directivity; these considerations lead us to a selection of loudspeaker enclosures with these properties. WST® technology ensures homogeneity in the coverage, an even tonal balance and adequate sound pressure levels throughout the hall.

Due to the coverage characteristics of the main system and the room layout, there isn't a need to supplement the main left & right array with a distributed system of smaller loudspeakers.

However, there is an area stage left with limited sight line to the stage that may need reinforcement

4 Speaker system identification.

Figures show the system location points within the venue. Each letter represents a part of the system as described in this section:

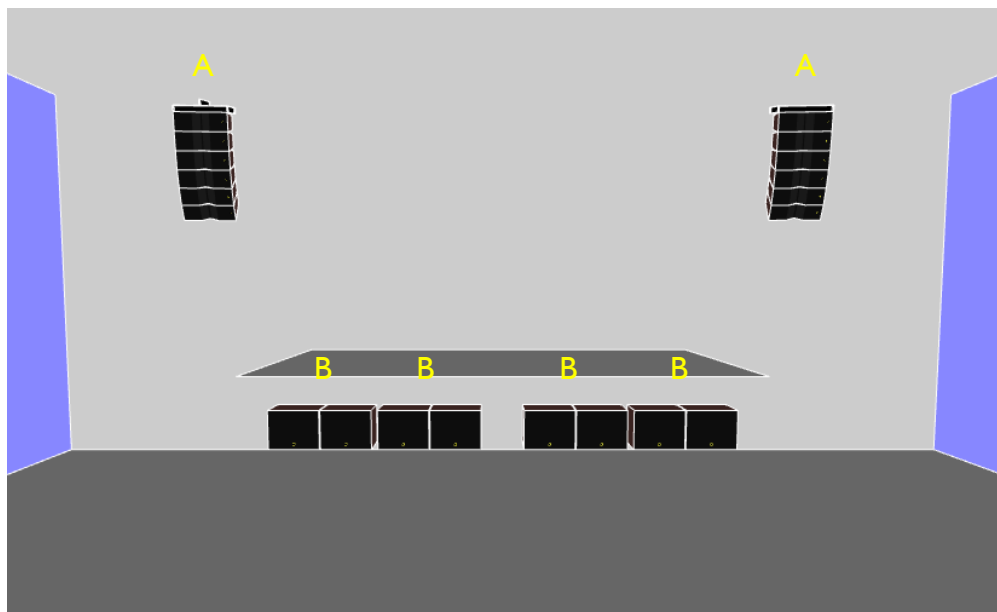

Figure: Main Left & Right
& Sub Bass



Positions #A&B

Indicates the position of the main stereo system, these consists of KARA line source enclosures with SB18i subwoofers ground stacked under the stage. The KARA enclosure features 2x8" low frequency drivers with a 3" HF driver attached to a DOSC waveguide and operates from 55 Hz to 20 kHz. Our K-shaped coplanar transducer configuration generates a symmetrical horizontal dispersion pattern of 110 degrees without secondary lobes over the entire frequency range. The dual bass-reflex tuned SB18i features a single 18" transducer that has a very high sensitivity and SPL, with progressive profile vents helping to reduce turbulence noise and distortion. Matched with correct amplifier preset and tuning we can ensure a smooth transition between the systems and an operating bandwidth extended down to 32Hz.

Sound sources defined.

Main Left/Right System (#A)

- 6 KARAI Line Source Arrays aside

Subs (#B)

- 8 SB18i Subwoofer Array

5 Amplified Controllers.

Power Consumption & Thermal Load

The Amplified Controllers power consumption and thermal load are given in Table below. They are dependent of load impedance and signal level characteristics. The current values are given for mains rated at **230 V**.

Amplified controller power consumption and thermal dissipation

Nominal voltage : <input type="text" value="230 V"/>			1/8 max. power - Nominal SPL			IDLE		Standby	
Type	4 ch. Loaded at	Qty	Current draw (A)	Thermal load (W)	Thermal load (BTU/hr)	Current draw (A)	Thermal load (W)	Current draw (A)	Thermal load (W)
LA8	2.7 or 4 Ω	<input type="text" value="3"/>	33	1800	6142	1.5	345	0.3	30
LA8	8 Ω	<input type="text" value="0"/>	0	0	0	0	0	0	0
LA4	4 Ω	<input type="text" value="0"/>	0	0	0	0	0	0	0
LA4	8 Ω	<input type="text" value="0"/>	0	0	0	0	0	0	0
LA4X	4 Ω or 8 Ω	<input type="text" value="0"/>	0	0	0	0	0	0	0
Total		3	33	1800	6142	1.5	345	0.3	30

Figure: 3 x LA8

Table: Maximum Output Power versus Mains Input Power

Note: An eighth of the maximum output power corresponds to a loud music program with a small dynamic range and 9 dB of headroom (IEC standard power rating). It is considered as the most common use of the system.

Network Architecture & Remote Control

The design of complex systems is made possible by the integration of the L-NET Ethernet-based network. Thanks to its high speed data transfer protocol of 100 Mbit/s, up to 253 units can be controlled and monitored in real-time by LA NETWORK MANAGER software. Multiple network topologies such as daisy-chain, star, and hybrid are quickly and easily configurable for full flexibility in the required system architecture.



The PC or Mac running LA NETWORK MANAGER and the units are connected to each other by using industry standard CAT5e U/FTP cables fitted with RJ45 connectors. Optimized for tablet PC use, LA NETWORK MANAGER relies on a purely graphical approach and allows placing units and groups in a workspace in a way that reflects

their location in the field. It is designed to quickly take the user through the workflow steps of Setup, Tuning, and Live by implementing the tools required for each task into their dedicated page. An advanced network engine allows automatic discovery of connected units. Multiple-group assignation capability, comprehensive real-time monitoring of events with log file, as well as numerous productivity tools complete the characteristics of a remarkably practical and application-oriented network management software.

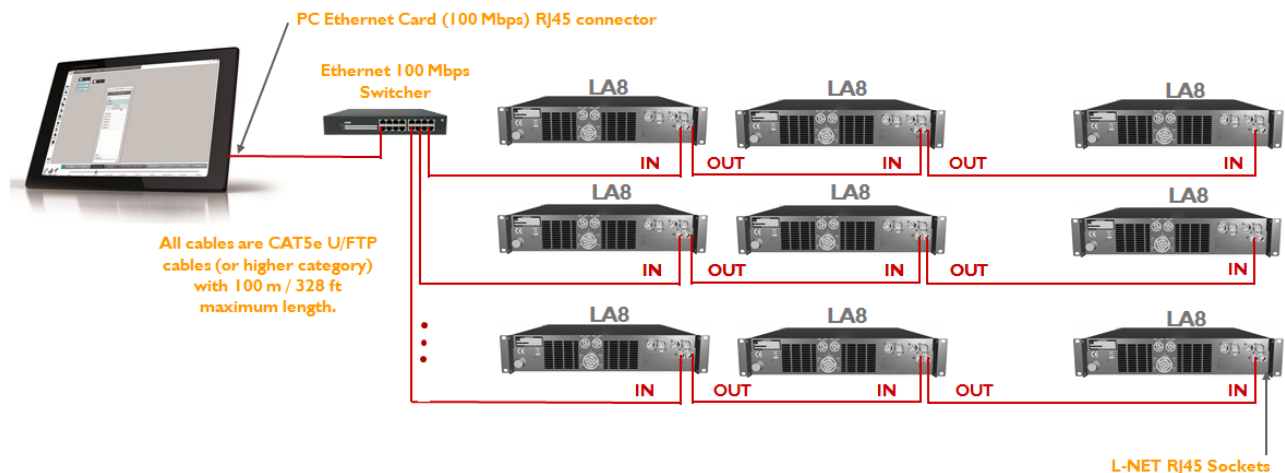

As a certified member of the CRESTRON ® and EXTRON ® partner programs, L-ACOUSTICS ® provides software modules allowing control integration into their automation systems, for the convenience of ultimate technology lifestyle in cultural and event centres, universities, houses of worship, sport facilities...

DSP

Proprietary algorithms are processed in a 32-bit floating point DSP engine at a 96 kHz sampling rate. A dedicated engineering approach combining IIR and FIR filters allows generating perfectly linearized phase curves and significantly improved impulse responses for an even more natural, transparent, and realistic sound experience. Two cascaded 24-bit A/D converters at the front-end yield a groundbreaking encoding dynamic of 130 dB.

The L-DRIVE protection system carries out a dual analysis of signal level in real-time and RMS. Under extreme conditions when component membranes reach the over-excursion zone or if the coil ensemble temperature reaches a critical point, L-DRIVE acts as a power regulator. As a result the amount of power delivered at any channel is adjusted to the dynamic and thermal capacity of each individual transducer. This optimizes the power resources while preserving the highest dynamic range.

Fallback Mode – Fail Safety

This possibility prevents sound cut in case of digital signal failure (no clock, loss of lock, invalid audio [validity bit], CRC error, bipolar encoding error, data slip), by allowing the amplified controller to automatically switch from AES/EBU to ANALOG inputs.

After the digital signal has returned to normal state, reverting to the AES/EBU input mode is not automatic and must be done manually by the user (by using LA NETWORK MANAGER software or AMX/CRESTRON control system, one click is sufficient for all concerned amplified controllers).

6 Loudspeaker Rigging Charts.

MECHANICAL DATA
(L-ACOUSTICS recommendations)
Results within 20% error

Max Dimensions (3D):

Width = 0.71 m
Depth = 0.8 m
Height = 1.63 m

MECHANICAL parameters:

Array weight: 141 kg
Total weight: 162 kg

Gravity center position:

XG: 4.03 m
YG: -0.33 m
ZG: 3.94 m

Loads on rigging:

Front linking points: 4.8 kg
Rear linking points: 136.2 kg

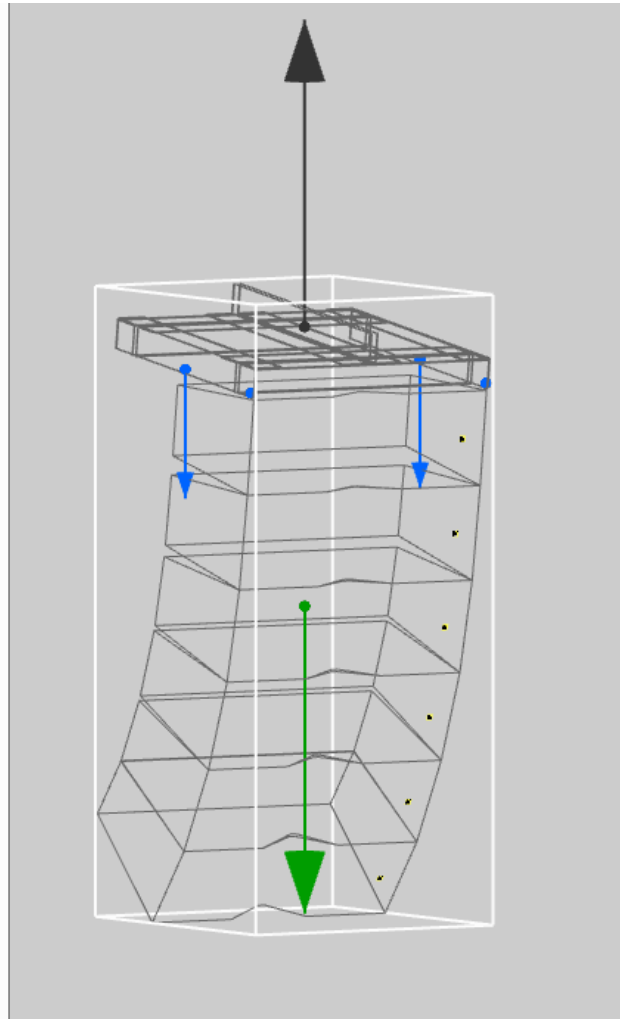

Mechanical & Rigging Data – Left & Right Array – KARAI

MECHANICAL DATA
(L-ACOUSTICS recommendations)
Results within 20% error

Max Dimensions (3D):

Width = 1.43 m
Depth = 0.7 m
Height = 0.54 m

MECHANICAL parameters:

Total weight: 104 kg

Gravity center position:

XG: -2.5 m
YG: -0.35 m
ZG: 0.27 m

Notes:

It is recommended to secure the array to the ground.

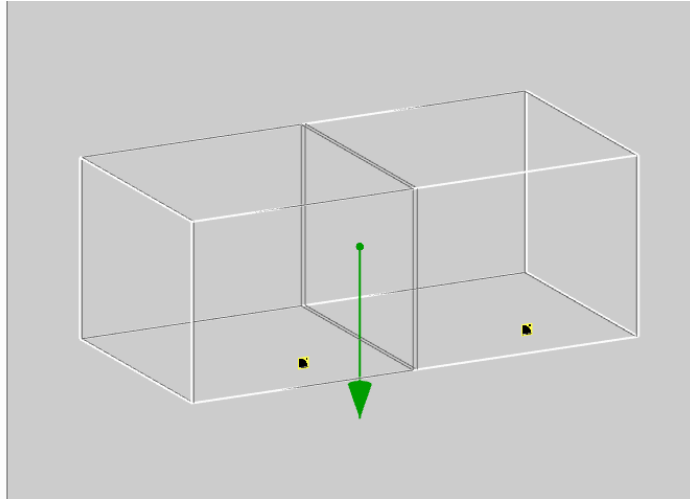

Mechanical & Rigging data – SB18i (ground stacked)

7 Acoustic Simulation.

Soundvision Software

The proposed project below was modelled using L-ACOUSTICS acoustic prediction software, SOUNDVISION. Room acoustics is not considered in prediction and plots provided have been presented to show direct field coverage.

Acoustical Simulation Program

Developed for sound designers, SOUNDVISION is dedicated to the acoustical and mechanical simulation of L-ACOUSTICS systems (WST line arrays and coaxial point source technologies).

Real time calculation of SPL and visualization of system coverage

SOUNDVISION allows the calculation of sound pressure level (SPL) coverage, SPL mapping and delay for complex sound system and venue configurations. Either horizontal (plan) or vertical (cut) views can be selected to enter room coordinates or to define loudspeaker placement/aiming. Impact coverage, SPL mapping or delay is then based on direct sound calculation over defined audience geometry.

Main array frequency contour

The following figure shows a cut view of the KARAI system with SPL target points. Target points surrounded with colours are the chosen location where frequency response is shown.



Figure: On axis SPL target points for each source

The following figure shows direct SPL frequency response in free field condition at corresponding distance with above figure. SPL values represent maximum SPL level with sweep-sine signal.

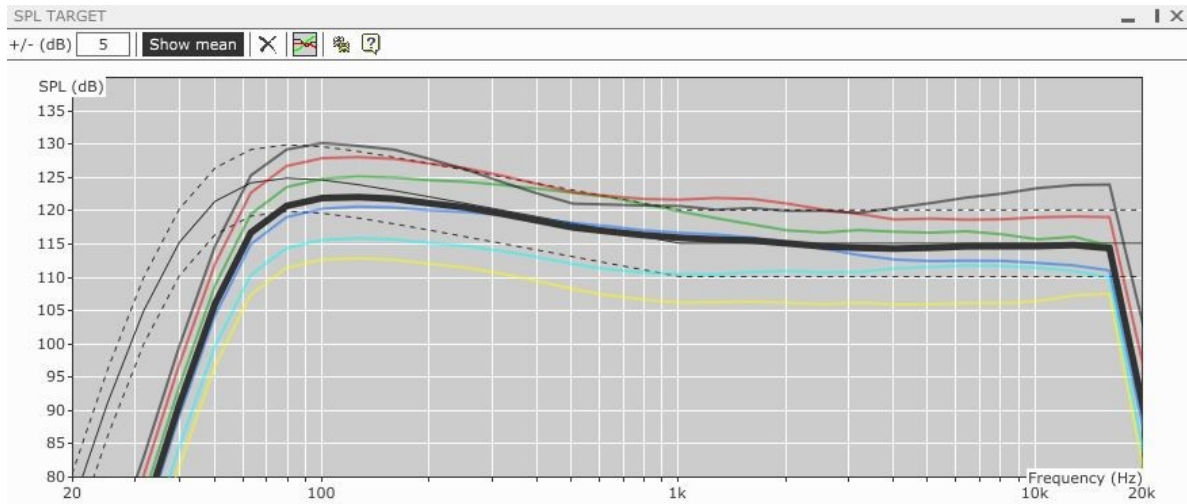

Soundvision SPL Mappings

The following graphs show direct SPL mapping over the audience for the entire system. The mappings are the result of broadband pink noise simulation from 20 Hz to 20 kHz in dBA (A weighted). The scale can be seen on the left side of each graph. The values represent the **maximum long term SPL (RMS)** achieved by the system. Peak values are 10dB above the show results.

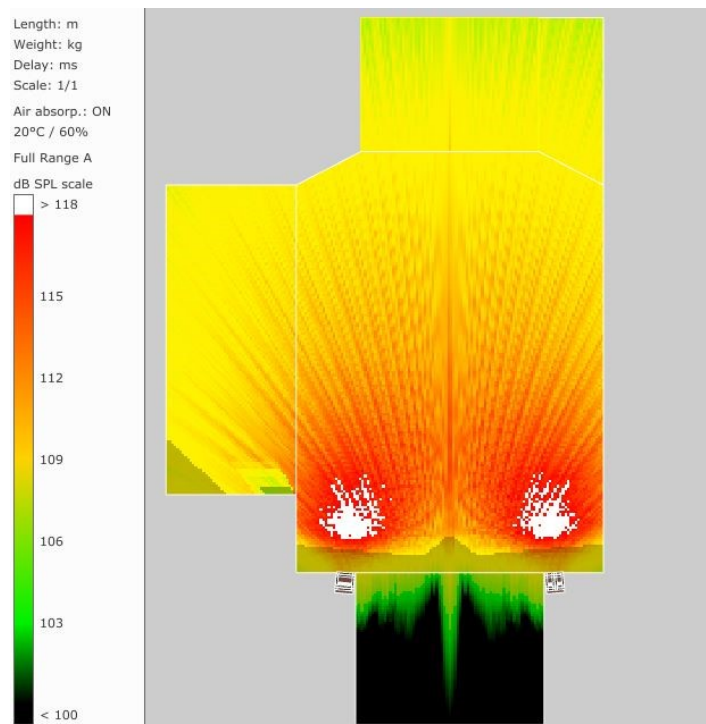
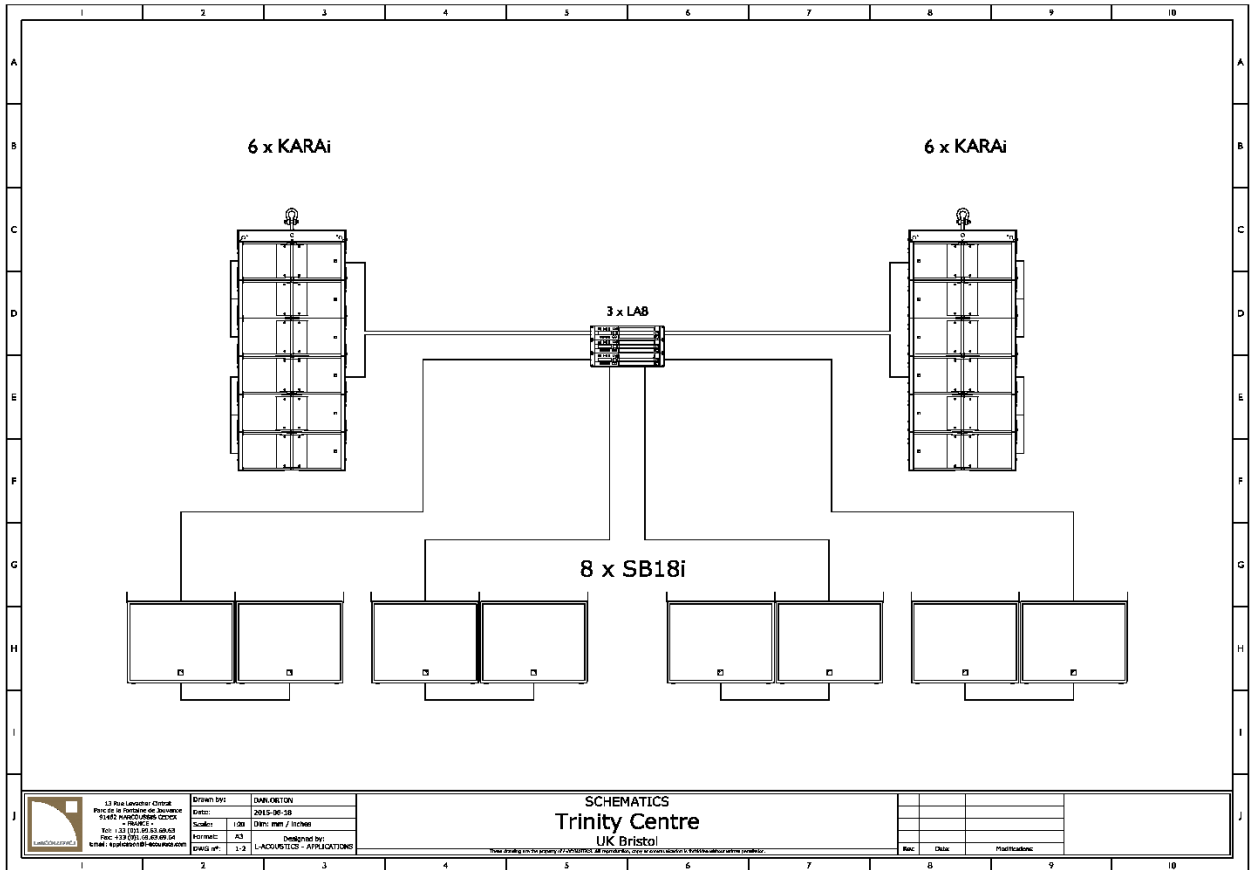

Figure: Mapping (Full range A weighted)

8 Schematics.



Main System

9 Technology Overview.

Ever since its creation 30 years ago and the invention of line source systems a few years later, L-Acoustics® has always strived to propose a clear and streamlined product line. The company philosophy is simple and revolves around the idea of engineering high quality purpose-built products designed to address well-defined practical needs. Today, L-Acoustics® products are based on three major technologies:

- The coaxial point sources, for short throw applications (XT and P)
- The constant curvature WST® line sources, for medium throw applications (ARCS® WIDE/FOCUS and ARCS® II)
- The variable curvature WST® line sources for longer throw applications (KIVA, KARA®, KUDO®, K2 and K1)

All three product families can be completed with a range of universal subwoofers designed for a wide variety of system formats, arrangements and LF contour characteristics.

Fill system – Coaxial Technology

L-ACOUSTICS® introduced the first coaxial loudspeaker for sound reinforcement in 1989. Initially designed for multi-purpose applications, the coaxial technology has demonstrated numerous advantages over classic two-way systems which typically suffer from interferences around the crossover point, resulting in lobing, uneven frequency and power response.



By superimposing the HF and LF acoustic centers, the coaxial design creates a virtual point source with significantly improved radiation characteristics. This is particularly valuable in distributed sound reinforcement applications where most of the listeners are located off the system axis. As the sound field of coaxial enclosures is stable over the entire frequency spectrum and in all directions, all listeners benefit from an even sonic performance within the enclosure bandwidth.

Such a technology is therefore very much adapted to front fill application, where most of the listeners are very close to the loudspeaker and 95% of them are outside the axis of the enclosure.

WST Technology – Constant Curvature Array

In 1995, L-ACOUSTICS® introduced constant curvature line sources with the implementation of the Wavefront Sculpture Technology® into the ARCS® system. At the heart of all ARCS® constant curvature enclosures is the DOSC® waveguide which morphs the spherical wavefront of the HF driver into a toric, isophasic wave.

As a result, ARCS® can be arrayed with a perfect acoustic coupling as opposed to classic trapezoidal enclosures which interfere with each other and produce comb filtering degrading sound quality outside of the array axis. When compared to conventional line source systems, ARCS® has the advantage of offering a perfect control over horizontal coverage and a smooth tonal balance over all frequencies. The wavefront emitted horizontally by the enclosure allows uniform coverage in increments.



The ARCS® line sources provide high SPL with perfect acoustic coupling, a solid LF performance and constant tonal balance over distance. In the coupling plane, the ARCS® line sources yield a razor-sharp directivity pattern, particularly valuable to sector audience fields while avoiding reflective surfaces. In the other plane, they provide a smooth directivity pattern.

WST Technology – Variable Curvature Array

In combination with WST®, coplanar symmetry (the equivalent of coaxial assembly for HF, MF and LF drivers in vertical arrays) provides a coherent wavefront over the entire horizontal coverage at all frequencies. This behaves as if the sound were radiated by a single, continuous and articulated ribbon. Any line source featuring L-ACOUSTICS® elements respects the coplanar symmetry and all WST® criteria over the entire sonic spectrum. This allows an exceptionally coherent sonic signature in very long-throw applications, beyond the limits of other systems. L-ACOUSTICS® has been designing reference line array systems for more than 20 years. L-ACOUSTICS® pioneered the field of modern line source array as early as 1993 with the introduction of Wavefront Sculpture Technology® on the legendary V-DOSC® system. Based on physical rules developed by Heil and Urban (AES 1992) the WST® theory defines five criteria for design and use of true line source arrays. At the heart of Wavefront Sculpture

Technology® is the internationally patented DOSC® waveguide, which morphs the spherical wavefront of the HF driver into a cylindrical, isophasic wave.

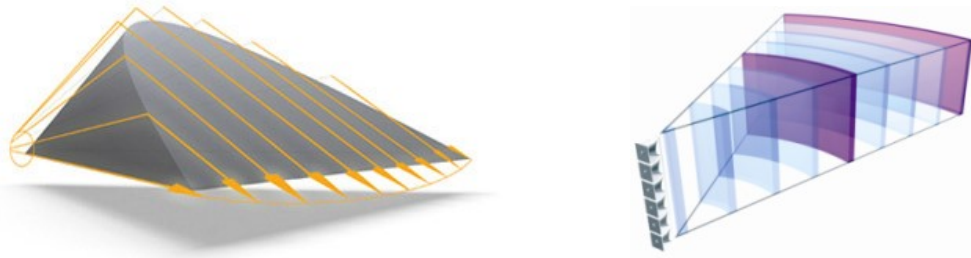

Any line source featuring L-ACOUSTICS® elements respects the coplanar symmetry and all WST® criteria on the entire sonic spectrum. This allows an exceptionally coherent sonic signature in very long throw applications, beyond the limits of other systems. L-ACOUSTICS® has been designing reference line array systems for more than 15 years.

Subwoofers

In 2004, L-ACOUSTICS® introduced a new diffraction model, the Distributed Edge Dipole. The DED was published in the AES Journal and provides a logical, predictable methodology for low frequency sound design. The DED model describes how a part of the wave produced by the speaker spreads toward the cabinet edges where it is diffracted with group delay and phase inversion.

The DED model is implemented for modeling the physics of cardioid applications and the size of enclosure. The latest subwoofer designs incorporate a vent with a progressive profile and ultra-low vibration walls for a significant gain in peak SPL, laminar airflow and drastic reduction of turbulence noise. L-ACOUSTICS® subwoofers benefit from the latest acoustic, signal processing and component innovations and deliver an exceptional level of performance while offering multiple modes of operation, whether on the road or in fixed installations.

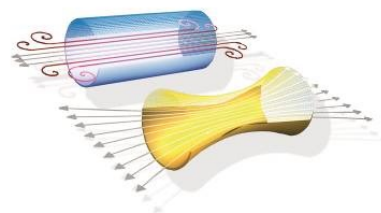

10 Datasheets.



KARAI

MODULAR WST® LINE SOURCE

The **KARAI** modular line source element has an operating frequency bandwidth from 55 Hz to 20 kHz. This response can be lowered down to 32 Hz with the addition of the SB18i low frequency extension.

KARAI features a 2-way, bi-amplified design and is equipped with 2 x 8" neodymium LF speakers in a bass-reflex tuned enclosure. The HF section features a 3" neodymium diaphragm driver coupled to a DOSC® waveguide.

The K-shaped coplanar transducer configuration generates a symmetric horizontal coverage of 110° without secondary lobes over the entire frequency range. The combination of coplanar symmetry and DOSC® waveguide allows the system to fulfil the 5 WST® criteria. Any KARAI line source can be curved up to a maximum of 10° for each element without breaking the inter-element acoustic coupling.

The KARAI enclosure is made of first grade Baltic birch plywood to ensure maximum acoustical and mechanical integrity. The enclosure meets the IP45 rating for protection from solids and liquids. The 4-point rigging system allows suspending up to 12 KARAI in a single array.

The KARAI system is driven by the dedicated LAB amplified controller which ensures active system linearization, intelligent transducer protection, and optimization for 3 operating modes:

- The "FULL RANGE" mode for standalone line sources arrays or distributed applications.
- The "HIGH-PASS" mode for fills.
- The "LOW EXTENSION" mode for SB18i/KARAI configurations.

The performance of KARAI depends upon the choice of electronic preset and physical system configuration.



Usable bandwidth (-10dB)	55 Hz - 20 kHz ([KARAI] preset)
Nominal directivity (-6dB)	Horizontal: 110° symmetric Vertical: Dependent upon number of elements and line source curvature
Maximum SPL¹	139 dB ([KARAI] preset)
RMS handling capacity	LF: 450 W HF: 80 W
Components	LF: 2 x 8" neodymium HF: 1 x 3" neodymium diaphragm compression driver Nominal impedance: LF = 8 ohms, HF = 8 ohms
Rigging²	Steel, certified for: 12 KARAI (BGV-C1 compliant) Angle increments: 0, 1, 2, 3, 4, 5, 7.5, 10°
Physical data	W x H/h x D: 713 x 250/186 x 380 mm 28.1 x 9.8/7.3 x 15 in Weight (net): 23.5 kg - 51.7 lbs Connectors: 2 x 4-point Speakon® Material: Baltic birch plywood Finish: Grey-brown RAL 8019® (KARAI) or Pure white RAL 9010® (KARAIW) Front: Polyester powder-coated steel grill, airtight® acoustically neutral fabric Protection rating: IP45 Rigging: Steel with zinc and polyester powder dual coating

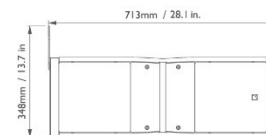

FRONT

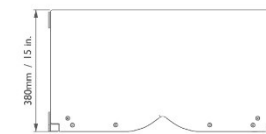

TOP

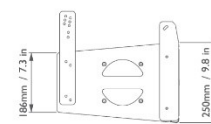

SIDE

¹ Peak level measured at 1m under free field conditions using 10 dB crest factor pink noise with specified preset and corresponding EQ settings
² Installation guidelines are specified in SOUNDVISION software designed to help with L-ACOUSTICS® product implementation.



SB18i

COMPACT HIGH POWER SUBWOOFER

The **SB18i** is the fixed installation subwoofer designed for WST® line sources and coaxial systems, lowering the combined system operating range down to 32 Hz. Its compact size and streamlined rigging make it extremely well suited for flown coupled configurations with KARAI®.

The association of a specifically designed 18" transducer with a dual bass-reflex tuned enclosure provides exceptional impact and high sensitivity, low thermal compression and reduced distortion. The vents feature a progressive profile allowing laminar airflow and reduced turbulence noise even at the very highest operating levels. These combined properties contribute to the sonic qualities of the SB18i in terms of precision and musicality.

The control and amplification of the SB18i is managed by either the LA4 or LA8 platform. The onboard DSP filtering encompasses advanced crossover functions, system EQ, and dual thermal and over-excursion protection of the transducer. The L-ACOUSTICS® amplified controllers offer the following drive modes:

- The "standard" mode using SB18i as a companion to KUDO®, KARAI®, KIVA-KILO, ARCS® and featuring a low-pass filter at 60 Hz ([SB18_60] preset) or closely coupled to KARAI®, ARCS® and XTi with a low-pass filter at 100 Hz ([SB18_100] preset).
- The "cardioid" mode using SB18i as a companion to KUDO®, KARAI®, KIVA-KILO, ARCS® and featuring a low-pass filter at 60 Hz ([SB18_60_C] preset) or closely coupled to KARAI®, ARCS® and XTi with a low-pass filter at 100 Hz ([SB18_100_C] preset).

The performance of the SB18i enclosure depends upon the choice of preset and physical system configuration. Made of high grade Baltic birch plywood, the cabinet features a pole mount socket for use with XTi or KIVA enclosures and standard M6 inserts for custom rigging options.



Low frequency limit (-10dB) 32 Hz ([SB18_100] preset)

Maximum SPL¹ 136 dB ([SB18_100] preset)

RMS handling capability 700 W

Components LF: 1 x 18" weather-resistant, (4" coil, aluminum die-cast basket, vented magnet design)
Nominal impedance: 8 ohms

Rigging² Steel, certified for: 8 SB18i with M-BUMPi (BGV-C1 compliant)

Physical data W x H x D: 713 x 543 x 700 mm - 28.1 x 21.4 x 27.6 in.
Weight (net): 50 kg - 110 lbs
Connectors: 2 x 4-point Speakon®
Material: Baltic birch plywood
Finish: Grey-brown, RAL 8019® (SB18i)
or Pure white RAL 9010® (SB18iW)
Front: polyester powder-coated steel grill,
airnet® acoustically neutral fabric
Rigging: steel with zinc and polyester powder dual coating

¹ Peak level measured at 1m under half space conditions using 10 dB crest factor pink noise with specified preset and corresponding EQ settings.

² Installation guidelines are specified in SOUNDVISION software designed to help with L-ACOUSTICS® product implementation.

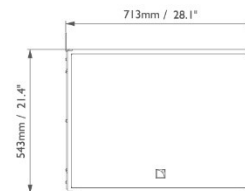

FRONT

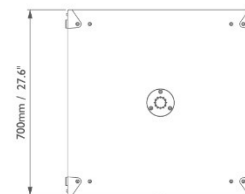

TOP

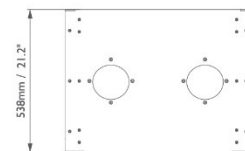

SIDE



LA8

AMPLIFIED CONTROLLER



The LA8 amplified controller belongs to the generation of high-end integrated controllers entirely dedicated to the comprehensive operation of L-ACOUSTICS® loudspeaker systems. The LA8 combines in a 2U lightweight chassis the resources of a 2 x 4 DSP engine driving four channels of amplification delivering up to 1800 watts each, a comprehensive library of factory presets, a user-friendly front panel interface, two I/O Ethernet connection ports for network remote control, a connection panel for audio inputs and speaker outputs, and an AES/EBU input board.

L-ACOUSTICS® preset library for LA8

- K1, K1-SB, KUDO
- KARA, ARCS II
- SB18, SB28
- I15XT HiQ
- Legacy products: V-DOSC, dV-DOSC, dV-SUB, ARCS, SB118, SB218

Full system drive capability

- Factory presets for active and passive modes.
- Flexible I/O matrix routing between the two inputs and the four amplified outputs

32-bit floating point DSP, 96 kHz sampling rate

- 24-bit cascaded A/D converters, 130 dB dynamic range
- Combined IIR/FIR algorithms
- Adjustable input and output delays
- Section dedicated to system equalization using LA NETWORK MANAGER
- L-DRIVE excursion and temperature real-time control
- Fixed Latency = 3.9 ms or 3.4 ms with AES/EBU

4-channel amplifier

- Universal switched mode power supply, 120 / 230 V (or 100 / 200 V for Japan)
- 4 x 1100 W / 8 Ω at 1% THD, all channels driven (4 x 1300 W peak)
- 4 x 1800 W/4 or 2.7 Ω at 1% THD, all channels driven (4 x 2500 W peak)
- Amplifier gain = 32 dB

Audio specifications

- Frequency response: 10 Hz – 30 kHz, -1.5/+0 dB at 8 Ω
- Output noise: -67 dBV (20 Hz – 20 kHz, A-weighted)
- Output dynamic range: 107 dB (20 Hz – 20 kHz, A-weighted)
- Max input level: +22 dBu (balanced, THD 1%)
- Channel separation: > 85 dB (1 kHz)
- Input impedance: 22 kΩ, balanced
- AES/EBU input board: refer to the **LA-AES3 spec sheet**

Dimensions

- H x W x D: 88 (2U) x 483 x 420 mm 3.5 (2U) x 19 x 16.5 in
- Weight (net): 12.2 kg 26.9 lbs
- Finish: black and anthracite gray

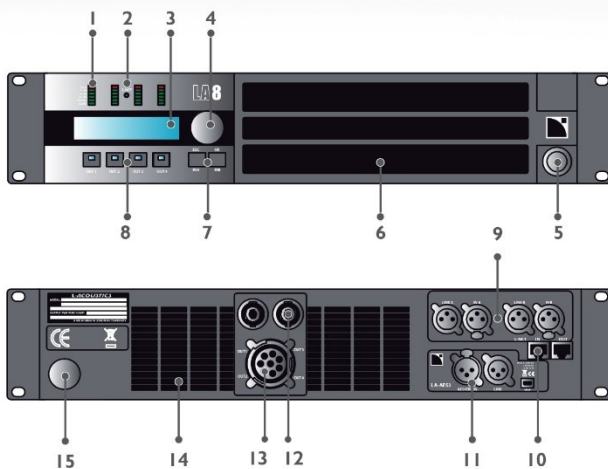

- 1 Clip and level bargraph LED
Signal presence LED
Load LED
- 2 L-NET network control LED
- 3 LCD screen
- 4 Nav/Edit encoder wheel
- 5 On/Off switch
- 6 Anti-dust cover
- 7 Input selection + menu keys
- 8 Output selection keys
- 9 Analog audio Input/Link connectors (XLR)
- 10 L-NET network I/O connectors (RJ45)
- 11 Digital audio Input/Link connectors (XLR)
- 12 SpeakON® output connectors
- 13 CA-COM® output connector
- 14 Fan grill
- 15 A/C power cord



11 Warranty.

All products or equipment supplied by L-ACOUSTICS® are covered against manufacturing defects and defects in the construction materials that would render them unsuitable for the purpose for which they were intended. Subject to the exclusions stated herein.

The duration of the warranty shall be 5 years commencing on the initial purchase date, as stated on the original L-ACOUSTICS® invoice. Both L-ACOUSTICS® customer service repairs and repair kits are covered by a 90 day limited warranty. The duration of the warranty is not affected or extended by the return of the product for repairs. This warranty does not cover obvious defects that have contaminated the product(s). Should such defect(s) be identified, the buyer shall notify L-ACOUSTICS® within 8 days from the date of delivery. Otherwise, the buyer is presumed to have fully accepted the delivered product as is.

Any warranty shall be limited solely to the replacement of defective parts and/or for the repair of parts judged necessary by L-ACOUSTICS®, and this choice is solely at the discretion of the manufacturer. The manufacturer does not accept responsibility for either any delay caused by the unavailability of products nor any financial compensation for labour costs incurred.

12 References.

REFERENCES

PERFORMING ARTS CENTER INSTALLATIONS PORTFOLIO

National Grand Theater	Beijing - China	Shanghai Oriental Arts Center	Shanghai - China
Damascus Opera House	Damascus - Syria	Shibuya-Ax Theater	Tokyo - Japan
Copenhagen Opera House	Copenhagen - Denmark	Staatstheater am Gartnerplatz	Munich - Germany
Oslo Theater Hall	Oslo - Norway	Suzhou Science and Cultural Centre	Suzhou - China
Pallas Theater	Athens - Greece	The Esplanade Theater Studio	Singapore
Salle Pleyel	Paris - France	The Old Student House	Helsinki - Finland
Cultural Village Theater	Doha - Qatar	The Royal Danish Theater	Copenhagen - Denmark
Radio City Music Hall	New York, NY - USA	Umi Theater of Shiki Theatrical Company	Tokyo - Japan
Salle Raoul-Jobin	Quebec - Canada	Vantaa Martinus Concert Hall	Vantaa - Finland
Royal Carre Theater	Amsterdam - Netherlands		
Royal Concert Hall	Glasgow - Scotland		
Salle des Etoiles Concert Hall	Monte-Carlo - Monaco		
Sejong Cultural Center	Seoul - Korea		
Seoul-Ax Concert Hall	Seoul - Korea		

For more reference information please visit:

www.l-acoustics.com/installations

www.l-acoustics.com/picture-gallery



Opéra Royal de Wallonie, Liège - Belgium



Salle Raoul-Jobin, Quebec - Canada

Al Raha Theater	Abu Dhabi - U.A.E	The Grande-Duchesse Concert Hall	Luxembourg
Alt Opera	Frankfurt - Germany	Guangzhou Opera House	Guangzhou - China
Austin Performing Arts Center	Austin, TX - USA	Helsinki Music Hall	Helsinki - Finland
Baku Opera	Baku - Azerbaidjan	Croatian National Theatre	Split - Croatia
Brno Theater	Brno - Czech Republic	Hyogo Arts and Cultural Hall	Hyogo - Japan
Carpenter Performing Arts Center	Long Beach, CA - USA	L'Orangerie du Botanique	Brussels - Belgium
Cemal Resit Rey Concert Hall	Istanbul - Turkey	La Cigale Club	Doha - Qatar
Chunmu and Pohang Arts Hall	Pohang - Korea	Lexington Opera House	Lexington, KC - USA
Cité de la Musique Concert Hall	Paris - France	Opéra Royal de Wallonie	Liège - Belgium
Danish Radio Concert Hall	Copenhagen - Denmark	Lille Grand Palais Congress Center	Lille - France
Figueira Casino Theater	Figueira Da Foz - Portugal	Queensland Performing Arts Center	Brisbane - Australia
Fox Theater Pomona	Pomona, CA - USA	Musical Dome	Cologne - Germany
Goteborg Concert Hall	Goteborg - Sweden	National Concert Hall	Dublin - Ireland
Grand Auditorium Cultural Center	Macao - China	National Doha Theater	Doha - Qatar



Copenhagen Opera House, Copenhagen - Denmark



Suzhou Science and Cultural Centre, Suzhou - China

13 Environmental Charter.



ENVIRONMENTAL CHARTER

ENVIRONMENTALLY FRIENDLY PRODUCT DEVELOPMENT

Since its founding in 1984, L-ACOUSTICS has created products with exceptional life and use cycles (20 years and more), with a philosophy of development that resists fads and frequent range renewals.

- 30,000 MTD systems in service since 1987
- 10,000 ARCS systems in service since 1995
- 8,000 V-DOSC systems in service since 1992
- 12,000 dV-DOSC systems in service since 1998.

As early as 1992, L-ACOUSTICS began promoting “Less is More” and anticipated the green economy wave by introducing the line source WST technology that would revolutionize the pro audio industry. With the introduction of the internationally-patented V-DOSC – the first modern line source array and “laser” of the acoustics field – L-ACOUSTICS pioneered the path for modern and ecological sound system solutions by:

- Focusing the acoustic energy on the audience areas and hence reducing noise pollution
- Minimizing the acoustical interferences between cabinets and therefore reducing acoustical and electrical energy waste
- Substantially reducing the weight and size of the systems for packaging, transportation and set up.

In the years following V-DOSC’s debut, the “walls of sound” that were commonplace to concerts before the '90s have almost disappeared thanks to the fact that most manufacturers have now adopted the line array paradigm created by L-ACOUSTICS. In addition to designing forward-thinking loudspeaker enclosures, L-ACOUSTICS today also develops and deploys modern amplification technologies for highly efficient power supply and sophisticated system control:

- High-powered Class D amplification of LA8 electronic amplified controllers
- Elevated energy efficiency close to 95% (versus 50% in the '80s).



TODAY: LINE SOURCES

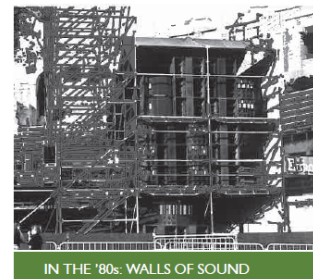

IN THE '80s: WALLS OF SOUND

This environmental commitment in the design of our products stems from a set of values and ethics that are clearly visible throughout all areas and levels of the company.

RECYCLING

- Wooden pallet recycling
- Paper and cardboard recycling: systematically sorted at every workstation and collected by specialized companies
- Recycling of computer equipment and consumables



SIMEA JOINERY, KESKASTEL - FRANCE



"GREEN" OUTDOOR TECHNICAL PLATFORM

MANUFACTURING, STORAGE AND SUBCONTRACTING

Assembly plants, storage, and R&D departments are all local. 100% of our suppliers and subcontractors are French or European and have not been relocated.

- SIMEA joinery: Alsace, France
- Electronic assembly: Germany
- Origin of the drivers: Italy, France and Germany
- Assembly of the loudspeakers: Marcoussis, France
- Origin of speaker parts: European region
- Wood: Finland and Lithuania

COMPANY PREMISES

- Acquisition of the woodlands next to the head office with a view to preserving the immediate environment
- Modern, well-insulated building
- Skylights for natural lighting in production areas and offices, with LED bulbs used where necessary
- Lighting activated by motion detectors in dark areas



ASSEMBLY IN THE MARCOUSSIS PREMISES - FRANCE



FLEET OF HYBRID VEHICLES: TOYOTA PRIUS

LOUDSPEAKER COMPONENTS

- All metallic parts used in the loudspeakers are recyclable
- Wood cabinets: no toxic product rejects
- Wood: L-ACOUSTICS participates in the reforestation program for the Baltic area
- Non-toxic water-based paints (technical specs available - WARNECKE/BOHM)

TRANSPORT AND PRODUCT PACKAGING

Logistics and packaging are organized in order to reduce emissions of greenhouse gases:

- Truck loads are optimized to reduce the number of trips
- Exclusive use of hybrid vehicles for our company car fleet (10 Toyota Prius)
- 30% reduction in primary and secondary packaging by suppliers
- Deposit system used on certain packaging
- Re-usable crates used for transportation between L-ACOUSTICS and our joinery, SIMEA
- Removal of all plastic films on SIMEA pallets

SOCIAL ACTIONS

Since 2000, the group's joinery, SIMEA, has maintained a partnership with the Oermingen detention center near Strasbourg in order to facilitate the rehabilitation of prisoners through learning a trade:

- Creation of a production workshop in the detention center
- Accompanying prisoners in their progress toward the working world outside the detention center before their release
- Recruitment of ex-offenders on a permanent basis.

Since 2006, L-ACOUSTICS has also developed an active rehabilitation policy through a partnership with a center for the training and recruitment of disabled staff, the Jean Moulin Centre in St Geneviève des Bois, Essonne, France.

- Six rehabilitation projects since 2006
- Two permanent recruitments.

L-ACOUSTICS also has an active policy for the employment of older workers:

- Older staff represented 9% of all recruitments in 2008/2009
- Special adaptation of working conditions.

FUTURE ACTIONS



L-ACOUSTICS is preparing to sign the Global Compact and is committed to aligning our strategies and operations with the ten UN principles on human rights, labor rights, environmental protection and the fight against corruption.

AND LAST BUT NOT LEAST...



In addition to the desire to combine eco-design, environmental preservation and the implementation of a socially responsible policy for all L-ACOUSTICS organizations, Christian Heil, president and founder, brings his personal contribution to the effort to reduce emissions of greenhouse gases when weather-permitting...

www.l-acoustics.com

L-ACOUSTICS FR
13 Rue Levacher Cintrat
91460 Marcoussis - FRANCE
Tel : +33 (0)1 69 63 69 63
Fax : +33 (0)1 69 63 69 64

L-ACOUSTICS DE
Steiermarker Str. 3-5
70469 STUTTGART - GERMANY
Tel: +49 (0) 711 89660 232
Fax: +49 (0) 711 89660 233

L-ACOUSTICS UK
PO. Box Adler Shine - Aston House
Cornwall Avenue - London N3 1LF
UNITED KINGDOM
Tel: +44 (0) 779 2811 442
Fax: +44 (1) 722 411 236

L-ACOUSTICS US
2201 Celsius Avenue, Unit E
Oxnard, CA 93030 - USA
Tel: +1 (805) 604 0577
Fax: +1 (805) 604 0858